

NON-METERED GREASE CONTROL HANDLES



413 080

**Grease control guns**

Steel and aluminum high pressure control gun with ergonomic grip. Maximum working pressure: 7140 psi. Inlet thread: 1/4" NPTF, outlet thread: 1/8" NPTF

**Model 413 077 - Grease control gun**

Grease control gun with rigid stem and 3 jaw connector (1124). 1/4" NPTF inlet.

**Model 413 080 - Grease control gun**

Grease control gun with rigid stem, 3 jaw connector (1124) and Z swivel (1105).

**Model 413 081 - Grease control gun**

Grease control gun with double steel braid reinforced rubber hose (1262) and 3 jaw connector (1124).

**Model 413 082 - Grease control gun**

Grease control gun with double steel braid reinforced rubber hose (1262), 3 jaw connector (1124) and Z swivel (1105).

IN LINE GREASE METER



**Model 411 103 - In line grease meter**

High pressure oval gear meter with digital display. Batch displays in ounces (up to 9999 oz) and permanent totalizer in pounds (up to 999999 lb). Batch display reset button. The meter can be easily calibrated in the field for maximum accuracy.

Works with two 1.5 V AAA alkaline batteries. Maximum pressure: 7140 psi (500 bar). Maximum flow range: up to 4.4 lb/min (2 Kg/min). Precision: ± 3,0 %. Inlet outlet connections: 1/8" NPTF.

DIGITAL-METERED GREASE CONTROL HANDLE



**Model 1177 - High pressure digitally metered grease control handle**

A grease control handle fitted with a high pressure in-line meter, model 411 103. This digital meter allows for better accuracy in greasing applications. Included is a double steel braid reinforced hose with a 3-jaw hydraulic connector, and Z-swivel, model 1105, with 1/4" NPTF inlet.

GREASE CONTROL GUN SWIVELS



To handle grease hoses easily even at high pressure. For best results, use a straight swivel between the pump and distribution hose and a Z swivel between the hose and grease control gun. Maximum working pressure: 7000 psi (500 bar).

**Model 1109 - Straight grease swivel. 1/4" x 1/4" NPTF**

**Model 1105 - "Z" grease swivel. 1/4" x 1/4" NPTF**

**Model 1104 - "Z" grease swivel. 1/4" NPTM x 1/2" x 27 M**

**Model 1108 - "Straight" grease swivel. 1/4" NPTM x 1/2" x 27 M**

**Model 414 200 - "L" grease swivel. 1/4" x 1/4" NPTF**

DOUBLE STEEL BRAID GREASE OUTLET HOSES



Double steel braid safety rubber hoses for use with air operated greasing equipment. Maximum working pressure: 7000 psi (500 bar). 1/8" NPTM threads.

**Model 142 020 - Steel braid outlet hose with 3 jaw connector. 10" long.**

**Model 142 030 - Steel braid outlet hose with 3 jaw connector. 12" long.**

**Model 142 040 - Steel braid outlet hose with 3 jaw connector. 16" long.**

**Model 142 050 - Steel braid outlet hose with 3 jaw connector. 18" long.**

**Model 142 200 - Steel braid outlet hose with 3 jaw connector. 80" long.**

**Model 140 020 - Steel braid outlet hose. 10" long.**

**Model 140 030 - Steel braid outlet hose. 12" long.**

**Model 140 040 - Steel braid outlet hose. 16" long.**

**Model 140 050 - Steel braid outlet hose. 18" long.**

**Model 140 200 - Steel braid outlet hose. 80" long.**

HIGH PRESSURE GREASE CONNECTORS.



For use with air operated pumps or hand greasing units on hydraulic type nipples (DIN 71412). Connector head, contact surface and jaws manufactured in hardened steel. Maximum working pressure: 7000 psi (500 bar). Connection thread: 1/8" NPTF (F).

**Model 1124 - 3 jaw high pressure grease connector.**

**Model 121 000 - 3 jaw high pressure narrow connector.**

GREASE STEMS



High-pressure grease outlet stems for use in air-powered greasing applications.

**Model 1122 - Angled pipe outlet with 1124 coupler 1/8" NPTM**

**Model 1120 - Angled pipe outlet 1/8" NPTM x 1/8" NPTM**

**STANDARD VOLUME NON-METERED OIL CONTROL HANDLES**



Aluminum body, non-metered oil control gun with ergonomically-designed handle. Buna-N rubber valve with progressive operation for comfortable operation even using 10:1 pumps. All guns include a ball bearing inlet swivel and conical fluid inlet screen. Maximum working pressure: 1500 psi (105 bar). Maximum delivery: 6.6 gpm (25 l/min). Fluid inlet thread: 1/2" NPSM (F).

MODEL NO.	APPLICATION	OUTLET TYPE	NOZZLE TYPE
<b>1130</b>	Gear oil	110° rigid swiveling	Manual
<b>1132</b>		None; handle w/ swivel only	None
<b>1134</b>	ATF (transmission fluid)	Straight flexible	Manual
<b>1171</b>	Oils	60° Angle rigid	Semi automatic
<b>1173</b>	All types of lubricants	Flexi hose w/ 90° swivel stem	Semi automatic

**MEDIUM VOLUME NON-METERED OIL CONTROL HANDLE**



**Model 363 088 - Medium flow non-metered oil control handle**

Aluminum body, non-metered oil control gun with ergonomically-designed handle. Buna-N rubber valve with progressive operation for comfortable operation even using 10:1 pumps. All guns include a ball bearing inlet swivel and are fitted with a high flow rigid outlet and semi-automatic non drip nozzle (1189). Maximum working pressure: 1500 psi (105 bar). Maximum delivery: 6.6 gpm (25 l/min). Fluid inlet thread: 1/2" NPSM (F).

**HIGH VOLUME NON-METERED CONTROL HANDLES**



**Model 1192 - High flow non-metered oil control handle**

High flow, non-metered oil control gun manufactured in aluminum. With double valve mechanism that allows small flow deliveries when the trigger is partially pressed and full flow delivery when the trigger is totally pressed. Lockable trigger and ball bearing inlet swivel. The handle includes a 60° angled rigid outlet with semiautomatic non drip nozzle (1189). Maximum working pressure: 1500 psi (105 bar). Maximum delivery: up to 11.7 gpm (45 l/min). Fluid inlet thread: 3/4" NPSM (F).

**Model 186 300 - High flow non-metered control handle for fluids**

Control gun with composite body and stainless steel valve mechanism for use with fluids like windshield washer, glycol solution and other water based fluids. Includes inlet swivel and flexible outlet with 90° stem. Maximum working pressure: 570 psi (40 bar). Maximum flow: 4 gpm (15 l/min). Inlet threads 1/2" NPSM (F).

**OIL BARS & ACCESSORIES**



**Model OB-1** - One tap oil dispensing bar

**Model OB-2** - Two tap oil dispensing bar

**Model OB-3** - Three tap oil dispensing bar

**Model OB-4** - Four tap oil dispensing bar

**Model 361 110** - Outlet kit to add a tap to existing bars

**Model 366 550** - In-line digital meter kit for oil bars

**Model 949 001** - Hose connector kit. Includes 2' connection hose, 1/2" NPTMBE swivel, and 1/2" NPTFBE medium pressure ball valve

STANDARD VOLUME DIGITAL METER CONTROL HANDLES



2162

Oval gear hose end meter with digital display for measured delivery of lubricants up to SAE 140. Meter is powered by two easily replaceable AAA 1.5 V alkaline batteries. This meter has a resettable batch display in quarts, a resettable totalizer in gallons and a permanent totalizer in gallons. Meters are factory calibrated but for maximum accuracy they can easily be calibrated in the field. The meter is flange coupled to a durable but lightweight oil control gun that incorporates a rugged ball bearing inlet swivel with an inlet filter. All hose end meters are supplied with a protective rubber shroud.

Maximum working pressure: 1500 psi (105 bar). Oil flow range: 1.3 to 5.25 gpm (5 to 20 l/min). Fluid inlet thread: 1/2" NPSM (F).

MODEL NO.	APPLICATION	OUTLET TYPE	NOZZLE TYPE
2159		No outlet; handle w/ meter and swivel only	None
2161	Motor oil	60° angle rigid	Semi automatic
2162	All lubricants	Flex hose w/ 90° swivel stem	Semi automatic
2165	ATF/Oils	Straight flexible	Manual
2163	Gear oil	110° angle rigid swiveling	Manual

MEDIUM VOLUME DIGITAL METER CONTROL HANDLE

365 088



**Model 365 088 - Medium flow digitally-metered control handle**

Oval gear digital meter for measured delivery of lubricants up to SAE 140. Meter is powered by two easily replaceable AAA 1.5 V alkaline batteries. This meter has a resettable batch display in quarts, a resettable totalizer in gallons, and a permanent totalizer in gallons. Meters are factory calibrated but for maximum accuracy they can easily be field-calibrated.

Maximum working pressure: 1500 psi (105 bar). Oil flow range: 5.5 gpm. Fluid inlet thread: 1/2" NPSM (F).

Includes a 2159 metered control handle with a high-flow 60° angle rigid outlet, non-drip tip (1189), protective shroud and 1/2" NPSM (F) threads.

HIGH VOLUME DIGITAL METER CONTROL HANDLES

365 652



**Model 365 652 - High flow digitally-metered control handle**

Oval gear hose end meter with digital display for measured delivery of lubricants up to SAE 140. Meter is powered by two easily replaceable AAA 1.5 V alkaline batteries. This meter has a resettable batch display in quarts, a resettable totalizer in gallons, and a permanent totalizer in gallons. Meters are factory calibrated but for maximum accuracy they can easily be calibrated in the field. The meter is coupled to a high delivery oil control gun that incorporates a rugged ball bearing inlet swivel with an inlet filter and 60° rigid outlet with semi automatic non drip nozzle. All hose end meters are supplied with a protective rubber shroud.

Maximum working pressure: 1500 psi (105 bar). Maximum flow range: up to 6.5 gpm (25 l/min). Fluid inlet thread: 3/4" NPSM (F).

**Model 1193 - Highest flow digitally-metered control handle (not shown)**

Model 2122 high flow 3/4" NPTF digital meter replaces standard model 2100 digital meter.

DIGITAL IN-LINE METERS



**Model 365 675 - Digital-metered control handle for fluids**

Oval gear hose end meter with digital display for measured delivery of fluids such as windshield washer, glycol solution and other water based fluids. Meter is powered by two easily replaceable AAA 1.5 V alkaline batteries. The meter has two separate displays in quarts, a resettable 4 digit batch display and a permanent totalizer in gallons. Meters are factory calibrated but for maximum accuracy they can easily be calibrated in the field. The in-line meter is coupled to a fluid control handle, model 186300.

Maximum working pressure: 570 psi (40 bar). Flow range: 5 to 1.3 to 4 gpm (15l /min). Fluid inlet thread: 1/2" NPSM (F).



Oval gear meter with mechanical, odometer style display for use with lubricants up to SAE 140. Partial reading up to 999.9 quarts and non-resettable totalizer registers in gallons. Meters are factory calibrated for maximum accuracy and include protective rubber shroud. The meter is flange coupled to a durable but lightweight oil control gun that incorporates a rugged ball bearing inlet swivel with filter.

Maximum working pressure: 1000 psi (70 bar). Oil flow range: 0.26 to 7.1 gpm (1 to 27 l/min). Fluid inlet and outlet threads: 1/2" NPSM (F).

**Models**

PART NO	APPLICATION	OUTLET TYPE	NOZZLE TYPE	UNIT
<b>1540</b>		None; handle w/ meter and swivel only	None	qts/gals
<b>1541</b>		None; handle w/ meter and swivel only	None	liters
<b>1544</b>	ATF/Oils	Straight flexible	Manual	qts/gals
<b>1545</b>	ATF/Oils	Straight flexible	Manual	liters
<b>1546</b>	All lubricants	Flex hose w/ 90° swivel stem	Semi automatic	qts/gals
<b>1547</b>	All lubricants	Flex hose w/ 90° swivel stem	Semi automatic	liters
<b>1548</b>	Motor Oil	60° angle rigid	Semi automatic	qts/gals
<b>1549</b>	Motor Oil	60° angle rigid	Semi automatic	liters

**IN-LINE OIL METER-ODOMETER STYLE MECHANICAL**



Oval gear meter with mechanical, odometer style display for use with lubricants up to SAE 140. Partial reading up to 999.9 quarts and non-resettable totalizer registers in gallons. Meters are factory calibrated for maximum accuracy and include protective rubber shroud.

Maximum working pressure: 1000 psi (70 bar). Oil flow range: 0.26 to 7.1 gpm (1 to 27 l/min). Fluid inlet and outlet threads: 1/2" NPSM (F).

**Model 1500 - Oval gear in-line meter with mechanical register – quarts / US gallons.**

**Model 1501 - Oval gear in-line meter with mechanical register – litres.**

**IN-LINE OIL METER-DIGITAL**



**Model 2100 - Digital in-line oil meter**

Oval gear meter with digital display. For use with lubricants up to SAE 140. Meter is powered by two easily replaceable AAA 1.5 V alkaline batteries. This meter has a resettable batch display in quarts, a resettable totalizer in gallons, and a permanent totalizer in gallons. Meters are factory calibrated but for maximum accuracy they can easily be calibrated in the field. Meter can count in liters, quarts, pints or gallons.

Maximum working pressure: 1500 psi (105 bar). Oil flow range: 1.3 to 5.25 gpm (5 to 20 l/min). Fluid inlet and outlet threads: 1/2" NPSM (F).

**HIGH FLOW IN LINE METERS: OILS, DIESEL & GLYCOL-BASED FLUIDS**



366 725

Oval gear in line meters with digital display. The meter has two separate displays in quarts, a resettable 4 digit batch display and a 6 digit permanent totalizer in gallons. Meters are factory calibrated but for maximum accuracy they can easily be calibrated in the field.

Meters are compatible with lubricants up to SAE 140, diesel and glycol solutions.

**Model 366 725 - High flow in line meter - 13.2 gpm**

Works with two AAA alkaline batteries.  
 Maximum working pressure: 1000 psi (70 bar)  
 Maximum working temperature: 140° F (60° C)  
 Flow range: minimum flow rate 1.45 gpm (5.5 l/min); maximum flow rate 13.2 gpm (50 l/min)  
 Accuracy: +/- 0.5 %  
 Pressure drop: 7 psi (0.5 bar)  
 Inlet and outlet threads: 1/2" NPSM (F)

366 726

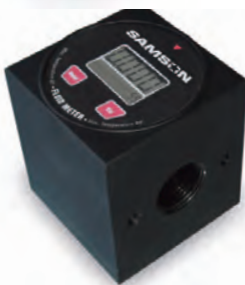

**Model 366 726 - High flow in line meter - 26.4 gpm**

Works with two AAA alkaline batteries.  
 Maximum working pressure: 430 psi (30 bar)  
 Maximum working temperature: 140° F (60° C)  
 Flow range: minimum flow rate 2.5 gpm (9.5 l/min); maximum flow rate 26.4 gpm (100 l/min)  
 Accuracy: +/- 0.5 %  
 Pressure drop: 7 psi (0.5 bar)  
 Inlet and outlet threads: 1" NPSM (F)

2122



**Model 2122 - High flow in line meter - 20 gpm**

3/4", 1500 psi. Meters in pints, quarts, liters or gallons. Rated to 1500 psi. 3/4" NPTF inlet and outlet threads. Runs on 2 N (1/2 AA) batteries.

2124



**Model 2124 - High flow in line meter - 30 gpm**

1", 1500 psi. Meters in pints, quarts, liters or gallons. Rated to 1500 psi. 1" NPTF inlet and outlet threads. Runs on 2 N (1/2 AA) batteries.

**PRE-SET OIL CONTROL HANDLE**



**Model 2199 - Heavy duty preset digital meter**

Electronic oval gear digital preset meter with 60° rigid outlet pipe, semi automatic nozzle and 1/2" NPTF screened inlet. Can be programmed to dispense in quarts, liters, pints, and gallons. A 5-digit LED shows accuracy to a hundredth of a gallon. Uses 4 replaceable AA batteries. Pre-calibrated at the factory, it is also easily field-calibrated if necessary. Can handle engine oil, gear oils up to SAE 140, antifreeze solution and hydraulic fluids.

Maximum working pressure: 1000 psi. Maximum flow rate: 8 gpm. Preset up to 99.9 units. Not suitable for outdoor use.

**TRADITIONAL MECHANICAL OIL METERS**



**Traditional Mechanical Pistol Grip Series**

This family consists of a count-up meter and a preset batch meter, both with mechanical dials. These meters are extremely durable for both indoor and outdoor applications. Fluid inlet: 1/2" NPSM (F); outlet: 1/2" NPTF. Flow rate up to 4 gpm. Includes model 1129 swivel. Rated to 1000 psi.

**Manual versions with locking trigger:**

- Model 1147:** 8 Pint dial oil meter with pint totalizer, 1131 Gear Oil rigid outlet included.
- Model 1148:** 16 Quart dial oil meter with gallon totalizer, 1141 Oil rigid outlet included.
- Model 1149:** 16 Quart dial oil meter with gallon totalizer, 1135 ATF flex hose included.
- Model 1150:** 16 Liter dial oil meter with liter totalizer, 1141 oil rigid outlet included.

**Pre-set Mechanical Versions:**

- Model 1152:** 60 Quart dial meter with gallon totalizer, 1141 oil rigid outlet included.
- Model 1153:** 60 Gallon dial meter with gallon totalizer, 1141 oil rigid outlet included.
- Model 1154:** 16 Quart dial meter with gallon totalizer, 1141 oil rigid outlet included.
- Model 1155:** 60 Liter dial meter with liter totalizer, 1141 oil rigid outlet included.

**TRADITIONAL MECHANICAL INLINE METERS**



Oscillating piston design for rugged dependability; for use with SAE 5 to 140 oils or glycol solutions. 1/2" NPTF inlet/outlet, 1000 psi max.

- Model 1196:** 8 Pint dial, totalizes in pints. For use with oils only.
- Model 1197:** 16 Quart dial, totalizes in gallons. For use with oils only.
- Model 1198:** 16 Liter dial, totalizes in liters. For use with oils only.
- Model 1199:** 16 Gallon dial totalizes in gallons. **For antifreeze applications.**

1131



1135



1128 / 1126



1139



**CONTROL HANDLE OUTLETS**

**Outlets for 1500 and 2100 Series Digital Meters**

MODEL NO.	APPLICATION	OUTLET TYPE	NOZZLE TYPE
<b>1131</b>	Gear oil	110° rigid swiveling	Manual
<b>1135</b>	ATF (transmission fluid)	Straight flexible	Manual
<b>1126</b>	All types of lubricants	Flexible with swiveling 90° stem	Semi automatic
<b>1128</b>	All types of lubricants	Flexible with swiveling 90° stem	Manual
<b>1139</b>	Motor oil	60° rigid	Semi automatic

**Outlet for all high-volume flow control handles**

MODEL NO.	APPLICATION	OUTLET TYPE	NOZZLE TYPE
<b>1189</b>	Lubricants, high delivery	60° rigid	Semi automatic

1138



1137



369 205



**Non drip nozzles**

- Model 1138** Semiautomatic non drip nozzle.
- Model 1137** Manual non drip nozzle
- Model 736 522** Semiautomatic high flow non drip nozzle for high volume outlet. For use with 365 652, 366 888, 1192 and 1193 high delivery hose end meters.
- Model 369 205** 90° angled adapter for use with manual operated non drip nozzles.

**Swivels**

1127



- Model 1123** 3/4" NPTF oil inlet swivel for aluminum high-flow handle. For use with 365 652, 366 888, 1192 and 1193 high delivery hose end meters.
- Model 1127** 1/2" NPTF oil inlet swivel for use in 1500 and 2100 series handles. For use with Samson hose end meters.
- Model 1129** 1/2" NPTF oil inlet swivel for use with model 2199 preset meter. For use with preset meters and other standard 1/2" inlet meters.

*This powerful console is designed for the shop that wants simple control of their fluids. The IMC offers ease of operation, great value, and several features not previously available in this category of control console. This category of console works with a pulser at the pump and solenoid control at the dispense point allowing only one dispense point per product to be operated. Samson's unique IMC is the perfect field replacement for this type of competitive console.*

**STANDARD FEATURES**

- Controls one or two products
- Inventory management on a declining balance
  - Allows initial inventory to be entered
  - Deducts each dispense
  - Manager enters each delivery
  - Alerts when inventory level is low
- When controlling two products, allows simultaneous dispense of both products
- Controls one to ten dispense points
- Allows one air outlet to be controlled so that air is only available during service operating hours
- Maximum quantity for preset dispense: 999 quarts
- Maximum quantity for free flow dispense: 999 quarts
- Maximum number of users: 200
- Two operation levels
  - User: able to only order a dispense
  - Manager: able to set inventory levels and perform management functions
- Three languages: English, Spanish, French
- Allows selection of US measurement (quarts) or metric (liters) measurement
- Key fob reader for use with optional key fob

**OPTIONAL FEATURES**

- PC interface with USB or Serial Port and IMS software
  - Displays tank inventory levels
  - When inventory level is low, alerts vendor via email
- External printer
- Allows connection of a two channel level sensor for used fluids; sounds alarm when tank is full
- Optional key fob for activation instead of PIN

**REPLACEMENT FOR COMPETITIVE CONSOLE**

- Drop in replacement in most instances
- Works with most pulsers
- In most instances, uses same pulser wire
- Works with AC or DC solenoids
- In most instances, uses same solenoid wire



**SYSTEM PACKAGES**

- 381192** One product: one dispense point console for stand alone use with one pulser and one dispense point kit
- 381193** Two product: two dispense point console for stand alone use with two pulsers and two dispense point kits
- 381194** One product: one dispense point console with PC interface, software & USB cable with one pulser and one dispense point kit
- 381195** Two product: two dispense point console with PC interface, software & USB cable with two pulsers and two dispense point kits

**INDIVIDUAL COMPONENTS**

- 381190** Console for stand alone use
- 381191** Console with PC interface, software & USB cable
- 380201** External printer
- 381400** Single channel alarm for used fluid tank
- 381401** Two channel alarm for used fluid tank
- 381158** Flashing red light for remote alert
- 381161** Dispense point kit: includes solenoid, filter, ready light and connection swivels in one convenient box

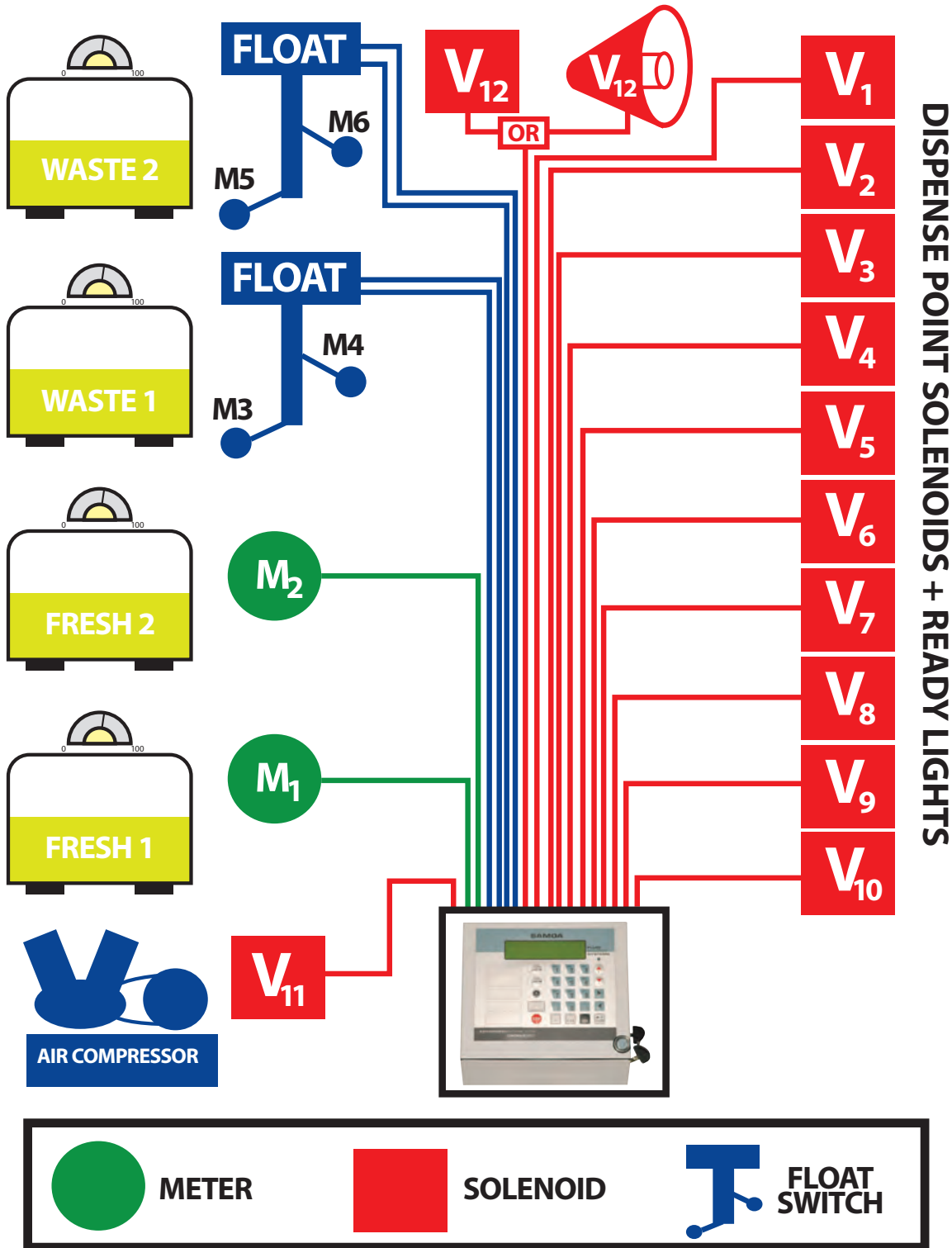

DISPENSE POINT SOLENOIDS + READY LIGHTS

- M3, M5, M6:** High level alarms that sound an alarm on the console and display alarm in window of console
- M6:** High level alarm that sounds an alarm on the console, displays alarm in window of console, and sends current to V12 for controlling an air solenoid on evacuation pump
- V11:** Programmable timer for controlling air supply to pumps

Fluid management in today's shops poses several challenges. As the size of the shop increases, properly dispensing and controlling fluids challenges older systems and equipment. Additionally, the increased cost of today's lubricants and the popularity of synthetics place a higher demand for the proper accounting of lubricant usage.

Samson is proud to lead the industry with our proven offering of inventory management products. From the simplest entry level console to sophisticated computerized management systems, we can help address the proper management of both new and used fluids.

A new concept:  
**THE ADVANCED MONITORING SYSTEM**

The Advanced Monitoring System (AMS), the software at the heart of our Inventory Management System (IMS), has been installed in several thousand facilities around the world. Based on our experience in the design of systems for fluid monitoring and the management of workshop activities, we have brought true innovation to an old concept. Through this experience and innovation, we have created a system designed to improve profitability through controlled fluid distribution and work-order accountability.

The Inventory Management System's ease of integration allows you to design any size installation using a minimum number of components, even adaptable down to a single-point dispense system. The modular design of the IMS makes it easy to install even the largest of systems, including more than 100 fluid outlets. It allows the integration of complementary functions, such as remote displays, stock level detectors, volumetric measuring probes, control access points and the automatic scheduling of any "on/off" function. This modular structure enables us to focus on adapting the equipment for the specific needs of each individual installation, reducing your cost, while guaranteeing the possibility of future evolution should new needs arise.

The network technology utilized by the IMS is the CANBUS network, which was originally developed to manage all of the functions of an automobile through one single cable. This technology gives the system a unique simplicity of installation, while offering the highest accuracy and speed of communications. CANBUS networks are used throughout industry, whenever a highly reliable network is required.

**IMS KEYPAD**

The IMS system can act as a stand alone system or be interfaced with a computer in the shop. Keypad may be mounted in the shop to provide technicians with access to dispense product or the keypad may be mounted in the parts room. Keypads may be activated by a PIN, an optional key fob, or an optional bar code scanner. The President keypad contains the system software module; one President keypad is required per system. Additional keypads may be ordered as needed.

To order a networked system, choose a President keypad that includes a PC interface. If a system is ordered to use in a stand alone configuration, a PC interface may be added at any time.

An optional internal thermal ticket printer provides a printed ticket with each dispense transaction. Fields included on the ticket are date/time, job number, product supplied, volume supplied, dispense point, technician name, vehicle number (optional), vehicle odometer (optional), and the remaining inventory of product. When product reaches a low level, ticket will have warning printed on it.



a

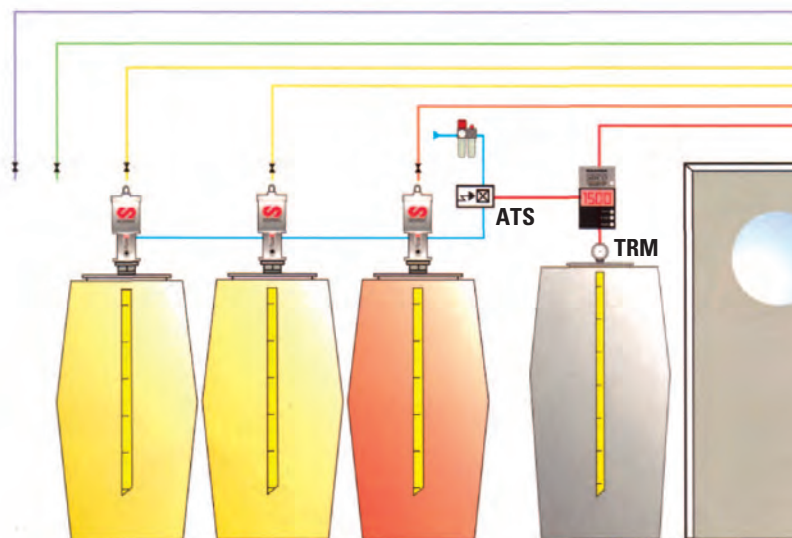

**INTELLIGENT FLOW CONTROL UNIT (IFCU)**

The IFCU is a dispense point controller located at each dispense point and includes the solenoid, pulser, filter, and display of product dispensed for that point. The filter is readily accessible for cleaning. The three digit large character super bright LED display shows the dispense point number when not in use and displays the quantity dispensed during use. Three LED indicator lights show the status of the dispense point.



*Dispense point control from 5 GPM for car and light truck shops all the way to 30 GPM for heavy duty applications*

**TANK ROOM MANAGER (TRM)**

Provides real time precise inventory for each tank. Accepts and measures new deliveries. IMS will allow up to four tank room managers in network allowing inventory management of sixteen tanks. When used with PC interface, the TRM provides a real time view of exact inventory on parts room computer. Allows emailing oil vendor when inventory level reaches predetermined level.

**ALARM TECH SUPERVISOR (ATS)**

Provides high level (or low level) management of any tank and manages up to four inputs. Unit will sound alarm when tank reaches programmed level; will also control air to evacuation pump and can control a remote alarm such as a flashing red light. Allows emailing used fluid hauler when inventory level reaches predetermined level.

**ACCESS CONTROL TERMINAL (ACT)**

Provides access control to doors with electronic locks. Requires key fob to activate, allows tracking of access to locations such as the lube storage room, essential tool room, or other secure areas. May also be used as a gate controller.

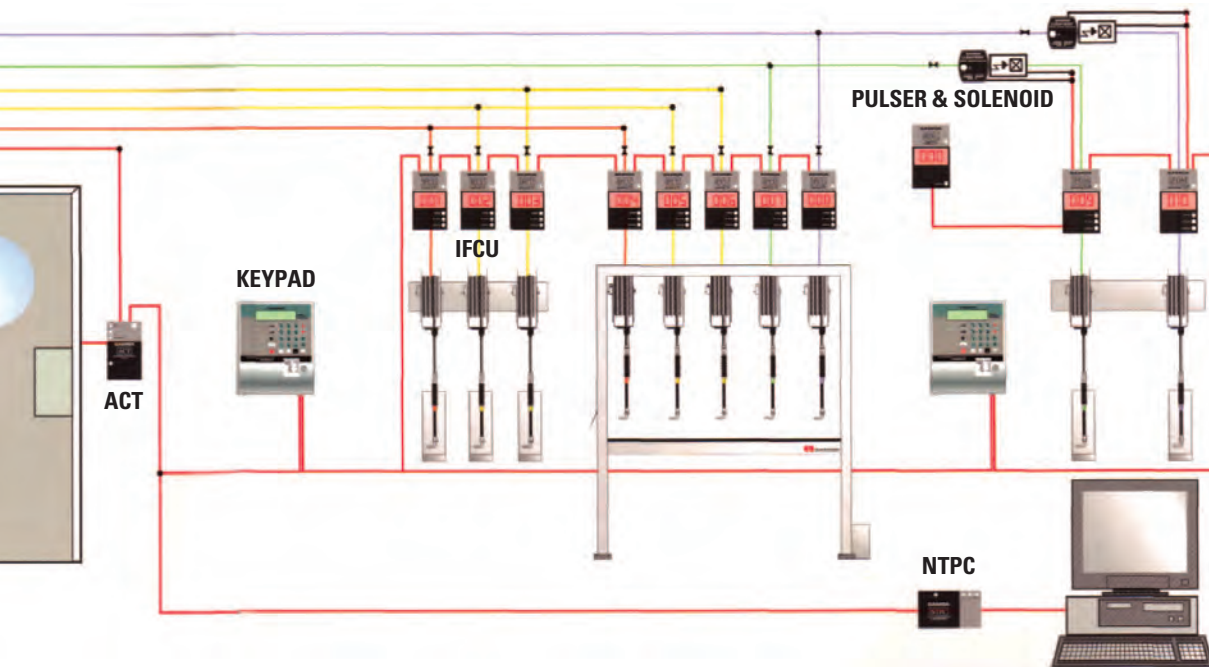

**KEYPADS**

- 381003** President keypad with PC interface (NTPC); and internal ticket printer
- 381005** President keypad with PC interface (NTPC); no internal ticket printer
- 381002** President keypad for stand alone use and internal ticket printer
- 381004** President keypad for stand alone use; no internal ticket printer
- 381000** IMS keypad without internal ticket printer
- 381001** IMS keypad with internal printer

**DISPENSE POINT CONTROL**

- 381501** IFCU for oil
- 381551** IFCU for water based products; 1/2" NPTF
- 381550** IFDM for custom applications; electronics only, needs pulser, solenoid, and filter
- 381502** IFDU for controlling motor fuel dispensers
- 381553** Pulser, solenoid, filter assembly for use with IFDM; 250 PSI, 3/4" NPTF, 20 GPM, 66.75 PPU
- 381554** Pulser, solenoid, filter assembly for use with IFDM; 250 PSI, 1" NPTF, 30 GPM, 66.75 PPU
- 381555** Pulser, solenoid, filter assembly for use with IFDM; 2000 PSI, 3/4" NPTF, 20 GPM, 66.75 PPU
- 381556** Pulser, solenoid, filter assembly for use with IFDM; 2000 PSI, 1" NPTF, 30 GPM, 66.75 PPU
- 381700** Remote Display Unit (RDU)

**TANK ROOM MANAGEMENT**

- 381153** Tank Room Manager (TRM) for use with IMS; manages up to four tanks
- 381157** Tank Room Manager (TRM) for stand alone use; manages up to four tanks
- 381404** Tank probe; one per tank
- 381315** Access Control Terminal (ACT); requires PIN or key fob to unlock door; controls entry to tank room, essential tool room, or other secure area
- 381152** Alarm Tech Supervisor (ATS) for use with IMS; manages up to four tanks
- 381156** Alarm Tech Supervisor (ATS) for stand alone use; manages up to four tanks
- 381400** One channel sensor
- 381401** Two channel sensor
- 381158** Flashing red alarm light for remote location

**SYSTEMS ACCESSORIES**

- 381901** Bar code scanner; connects to keypad for data entry
- 381102** Power supply; must be added to system when more than 8 dispense points per keypad
- 381905** Set of five key fobs for activating system in lieu of PIN entry
- 381906** Box of 15 rolls of thermal paper for keypad printer
- 380201** External printer; must be within 100' of a system keypad
- 381958** 1000' Spool of network cable
- 381999** One day of on-site technical assistance
- 381960** Serial to USB connector kit with software

PULSE METERS



1061

**Model 1071 - 100 PPU Oval Gear Pulse Meter**

Oval gear pulse meter for oils and glycol solutions. 1/2" inlet/outlet.

**Model 600 601 - 328 PPU Pulse Meter for windshield washer solution**

Pulse meter manufactured in stainless steel with Viton seals for use with methanol based WW solutions. 1/2" inlet/outlet. Max pressure 215 psi.

**Model 1061 - 10 PPQ Traditional Pulse Meter**

Traditional pulse meter for oils and glycol solutions. 1/2" inlet/outlet

SOLENOIDS



1065

**Model 1065 - 24 VAC/DC Oil Solenoid - Normally Closed (NC)**

Medium pressure NC oil solenoid for use on AC or DC systems; internally rectified. Equipped with a protective screen. 1/2" inlet/outlet. Max 3000 psi.

**Model 1064 - 24 VAC Air/Water Solenoid - Normally Closed (NC)**

Low pressure brass bodied NC solenoid for use as an air solenoid or for water based solutions like WW fluid or Coolant. 1/2" inlet/outlet. Max 300 psi.

**Model 1074- 24 VDC Air/Water Solenoid - Normally Closed (NC)**

Low pressure brass bodied NC solenoid for use as an air solenoid or for water based solutions like WW fluid or Coolant 1/2" inlet/outlet. Max 300 psi.

**Model 107 042 - 24 VAC Air/Water Solenoid - Normally Opened (NO)**

Low pressure brass bodied NO solenoid for use as an air solenoid to control waste oil pumps. 1/2" inlet/outlet. Max 300 psi.

OTHER ACCESSORIES



1068

**Model 1068 - Ready Light**

24 VAC bulb mounted in a small box. Wires in series with solenoid at dispense point to indicate 'Reel On' condition to technician.



1069

**Model 1069 - Y Strainer**

1/2" NPTF cleanable screened filter for mounting upstream of oil solenoid. Rated to 250 psi.